

MOSFET Driver Is Reverse-Battery Protected

MOSFET power-switch drivers must be protected from a reverse-battery connection. A small rectifier diode can protect against reversed batteries, but that approach is generally unacceptable for systems in which battery life is crucial. For a 6V battery, the diode's forward voltage drop (0.6V to 0.7V typical) produces a constant power loss of approximately 10%, which increases with dwindling battery voltage. An improvement over single-diode protection is shown.

MOSFET power-switch drivers must be protected from a reverse-battery connection. A small rectifier diode can protect against reversed batteries, but that approach is generally unacceptable for systems in which battery life is crucial. For a 6V battery, the diode's forward voltage drop (0.6V to 0.7V typical) produces a constant power loss of approximately 10%, which increases with dwindling battery voltage.

Figure 1 illustrates an improvement over single-diode protection. A p-channel MOSFET (Q1) protects the driver (U1) from reverse-battery insertion. Q1's low on-resistance of 10m Ω or less produces a forward-voltage drop of only a few millivolts (vs. hundreds of millivolts for a diode). Thus, substituting a MOSFET for the diode provides an immediate improvement in efficiency.

Connecting a positive battery voltage to the drain of Q1 produces forward bias in its body diode, which clamps the source voltage one diode drop below the drain voltage. When the source voltage exceeds Q1's threshold voltage, Q1 turns on. Once the FET is on, the battery is fully connected to the system and can deliver power to U1 and the load.

An incorrectly inserted battery reverse-biases the body diode. The source remains at ground potential and the gate is connected to ground, so Q1 remains off, disconnecting the reversed battery from the system. V_{DS} equals the full negative battery voltage when you insert the battery backwards, and in some applications Q1 may have to withstand transient levels many times the battery voltage. Q1 must be able to withstand V_{GS} and V_{DS} voltages at least equal to the maximum battery voltage.

Besides reverse-battery protection, the Figure 1 circuit also protects against reverse load current at startup. Q3 ensures that no load current flows until U1 enables both n-channel MOSFETs (Q2 and Q3). Reverse load current can cause Q1 to turn on inadvertently, leaving the circuit unprotected against reversed-battery connections.

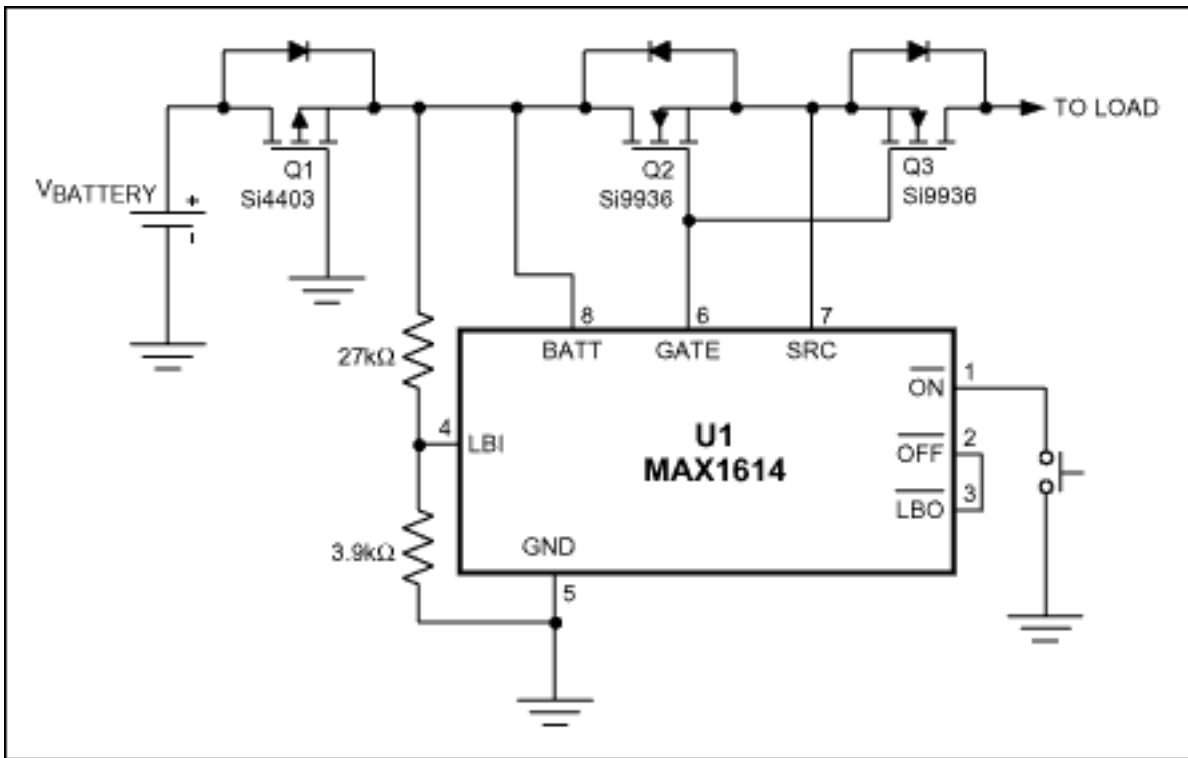

Figure 1. An external p-channel MOSFET (Q1) easily protects this MOSFET driver (U1) against reversed batteries and reversed load current.

More Information

MAX1614: [QuickView](#) -- [Full \(PDF\) Data Sheet](#) -- [Free Samples](#)